

# Owner's Manual

## Thunderbolt™ 3 Travel Dock with HDMI, DisplayPort, USB-A and Gigabit Ethernet Hub Ports

Model: MTB3-DOCK-01

Este guía esta disponible en español en la página de Tripp Lite:  
[www.tripplite.com/support](http://www.tripplite.com/support)

Ce guide est disponible en français sur le site Web de Tripp Lite :  
[www.tripplite.com/support](http://www.tripplite.com/support)

Русскоязычная версия настоящего краткого руководства представлена  
на веб-сайте компании Tripp Lite по адресу: [www.tripplite.com](http://www.tripplite.com)

### WARRANTY REGISTRATION

Register your product today and be automatically entered to win an ISOBAR surge protector in our monthly drawing!



[www.tripplite.com/warranty](http://www.tripplite.com/warranty)



1111 W. 35th Street, Chicago, IL 60609 USA • [www.tripplite.com/support](http://www.tripplite.com/support)

Copyright © 2019 Tripp Lite. All rights reserved.

## Product Features

- Supports USB DisplayPort Alternate Mode for connecting an HDMI monitor
- HDMI port supports 4K UHD video resolutions up to 4096 x 2160 @ 60 Hz and HDMI 2.0
- DisplayPort supports 4K UHD video resolutions up to 4096 x 2160 @ 60 Hz and DP 1.2
- Thunderbolt 3 connector supports data transmission rates up to 40 Gbps
- Ethernet port supports true Gigabit network speeds
- USB-A port supports data transfer rates up to 5 Gbps

## Package Contents

- MTB3-DOCK-01
- Owner's Manual

## System Requirements

- Computer with Thunderbolt 3 port that supports USB DisplayPort Alternate Mode
- DisplayPort or HDMI monitor\*
- Ethernet network with speeds up to 10/100/1000 Mbps

\*Both ports can be used at once to transmit 4K video. Requires High-Speed HDMI and DisplayPort cables (sold separately, see Optional Accessories for more information).

## Optional Accessories

- N201-Series Cat6 Gigabit Snagless Patch Cables
- P566-Series HDMI to DVI Adapter Cables
- P569-XXX-CERT Series Certified High-Speed HDMI Cables
- P580-XXX Series DisplayPort Cables
- U322-Series USB 3.0 A/B Device Cables

# Product Overview

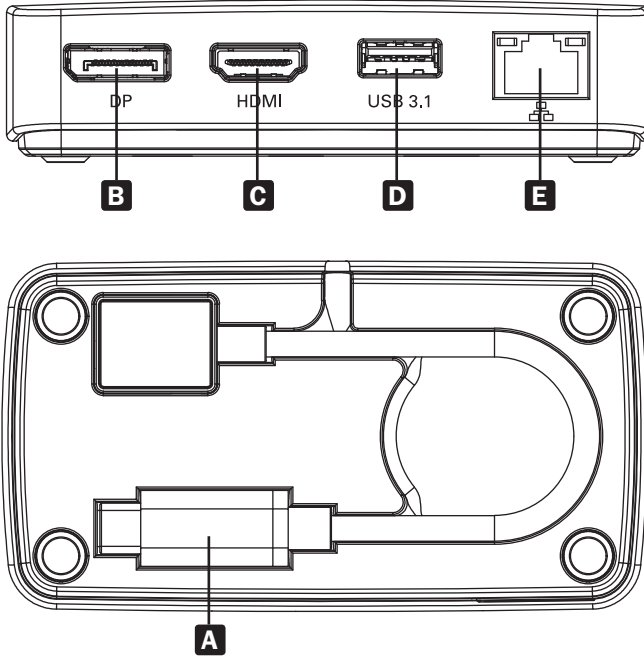

- A** Thunderbolt 3 USB-C Male Connector
- B** DisplayPort 1.2 Port
- C** HDMI 2.0 Port
- D** USB-A 3.1 Port
- E** Gigabit Ethernet Port

# Installation

## Notes:

- See **Optional Accessories** section for suggested cables.
  - When the unit is connected to the Thunderbolt 3 port on your computer and to a network via Cat5e/6 cabling, a network connection will automatically be established. If no connection is made, one can be established manually by going to your computer's network settings page. For example, when using a Mac, navigate to the Network section found in System Preferences, click the 'Assist Me' button to open the Network Setup Assistant, then follow the prompts to establish a connection.
  - Both HDMI and DisplayPort monitors can be connected at the same time for transmitting 4K video to two displays at once.
- 1.** Connect the built-in Thunderbolt 3 USB-C cable to the Thunderbolt 3 port on your laptop, tablet or other device.
  - 2.** Use an HDMI cable to connect a monitor or display to the unit's HDMI port.
  - 3.** Use a DisplayPort cable to connect a monitor or display to the unit's DisplayPort.
  - 4.** Connect a USB peripheral to the unit's USB-A port.
  - 5.** For an Ethernet connection, use Cat5e/6 UTP cable to connect to the unit's RJ45 port.

# Specifications

## Input Connector

Thunderbolt 3	USB-C (Male)
---------------	--------------

## Output Connectors

USB-A	USB-A (Female)
-------	----------------

DisplayPort	DisplayPort (Female)
-------------	----------------------

HDMI	HDMI (Female)
------	---------------

Ethernet	RJ45 (Female)
----------	---------------

## Environmental

Operating Temperature	32° to 104°F (0° to 40°C)
-----------------------	---------------------------

Operating Humidity	10% to 85% RH, Non-Condensing
--------------------	-------------------------------

Storage Temperature	-4° to 185°F (-20° to 85°C)
---------------------	-----------------------------

Storage Humidity	5% to 90% RH, Non-Condensing
------------------	------------------------------

# Warranty and Product Registration

## 3-Year Limited Warranty

Tripp Lite warrants its products to be free from defects in materials and workmanship for a period of three (3) years from the date of initial purchase. Tripp Lite's obligation under this warranty is limited to repairing or replacing (at its sole option) any such defective products. To obtain service under this warranty, you must obtain a Returned Material Authorization (RMA) number from Tripp Lite or an authorized Tripp Lite service center. Products must be returned to Tripp Lite or an authorized Tripp Lite service center with transportation charges prepaid and must be accompanied by a brief description of the problem encountered and proof of date and place of purchase. This warranty does not apply to equipment, which has been damaged by accident, negligence or misapplication or has been altered or modified in any way.

EXCEPT AS PROVIDED HEREIN, Tripp Lite MAKES NO WARRANTIES, EXPRESS OR IMPLIED, INCLUDING WARRANTIES OF MERCHANTABILITY AND FITNESS FOR A PARTICULAR PURPOSE. Some states do not permit limitation or exclusion of implied warranties; therefore, the aforesaid limitation(s) or exclusion(s) may not apply to the purchaser.

EXCEPT AS PROVIDED ABOVE, IN NO EVENT WILL Tripp Lite BE LIABLE FOR DIRECT, INDIRECT, SPECIAL, INCIDENTAL OR CONSEQUENTIAL DAMAGES ARISING OUT OF THE USE OF THIS PRODUCT, EVEN IF ADVISED OF THE POSSIBILITY OF SUCH DAMAGE.

Specifically, Tripp Lite is not liable for any costs, such as lost profits or revenue, loss of equipment, loss of use of equipment, loss of software, loss of data, costs of substitutes, claims by third parties, or otherwise.

## Product Registration

Visit [www.triplite.com/warranty](http://www.triplite.com/warranty) today to register your new Tripp Lite product. You'll be automatically entered into a drawing for a chance to win a FREE Tripp Lite product!\*

\* No purchase necessary. Void where prohibited. Some restrictions apply. See website for details.

## FCC Notice, Class B

This device complies with part 15 of the FCC Rules. Operation is subject to the following two conditions:

(1) This device may not cause harmful interference, and (2) this device must accept any interference received, including interference that may cause undesired operation.

Note: This equipment has been tested and found to comply with the limits for a Class B digital device, pursuant to part 15 of the FCC Rules. These limits are designed to provide reasonable protection against harmful interference in a residential installation. This equipment generates, uses and can radiate radio frequency energy and, if not installed and used in accordance with the instructions, may cause harmful interference to radio communications. However, there is no guarantee that interference will not occur in a particular installation. If this equipment does cause harmful interference to radio or television reception, which can be determined by turning the equipment off and on, the user is encouraged to try to correct the interference by one or more of the following measures:

- Reorient or relocate the receiving antenna.
- Increase the separation between the equipment and receiver.
- Connect the equipment into an outlet on a circuit different from that to which the receiver is connected.
- Consult the dealer or an experienced radio/TV technician for help.

Any changes or modifications to this equipment not expressly approved by Tripp Lite could void the user's authority to operate this equipment.

## WEEE Compliance Information for Tripp Lite Customers and Recyclers (European Union)



Under the Waste Electrical and Electronic Equipment (WEEE) Directive and implementing regulations, when customers buy new electrical and electronic equipment from Tripp Lite they are entitled to:

- Send old equipment for recycling on a one-for-one, like-for-like basis (this varies depending on the country)
- Send the new equipment back for recycling when this ultimately becomes waste

Use of this equipment in life support applications where failure of this equipment can reasonably be expected to cause the failure of the life support equipment or to significantly affect its safety or effectiveness is not recommended.

Tripp Lite has a policy of continuous improvement. Specifications are subject to change without notice. Photos and illustrations may differ slightly from actual products.





1111 W. 35th Street, Chicago, IL 60609 USA • [www.tripplite.com/support](http://www.tripplite.com/support)